

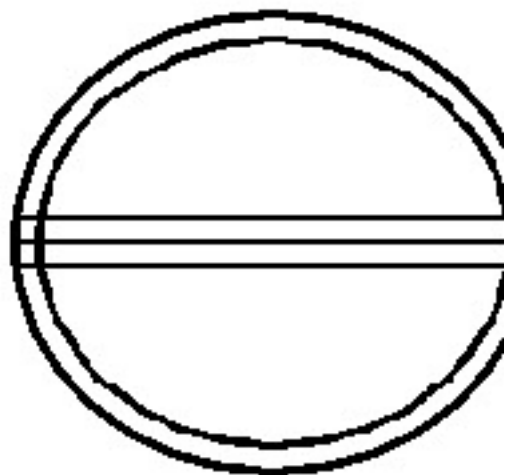

F6

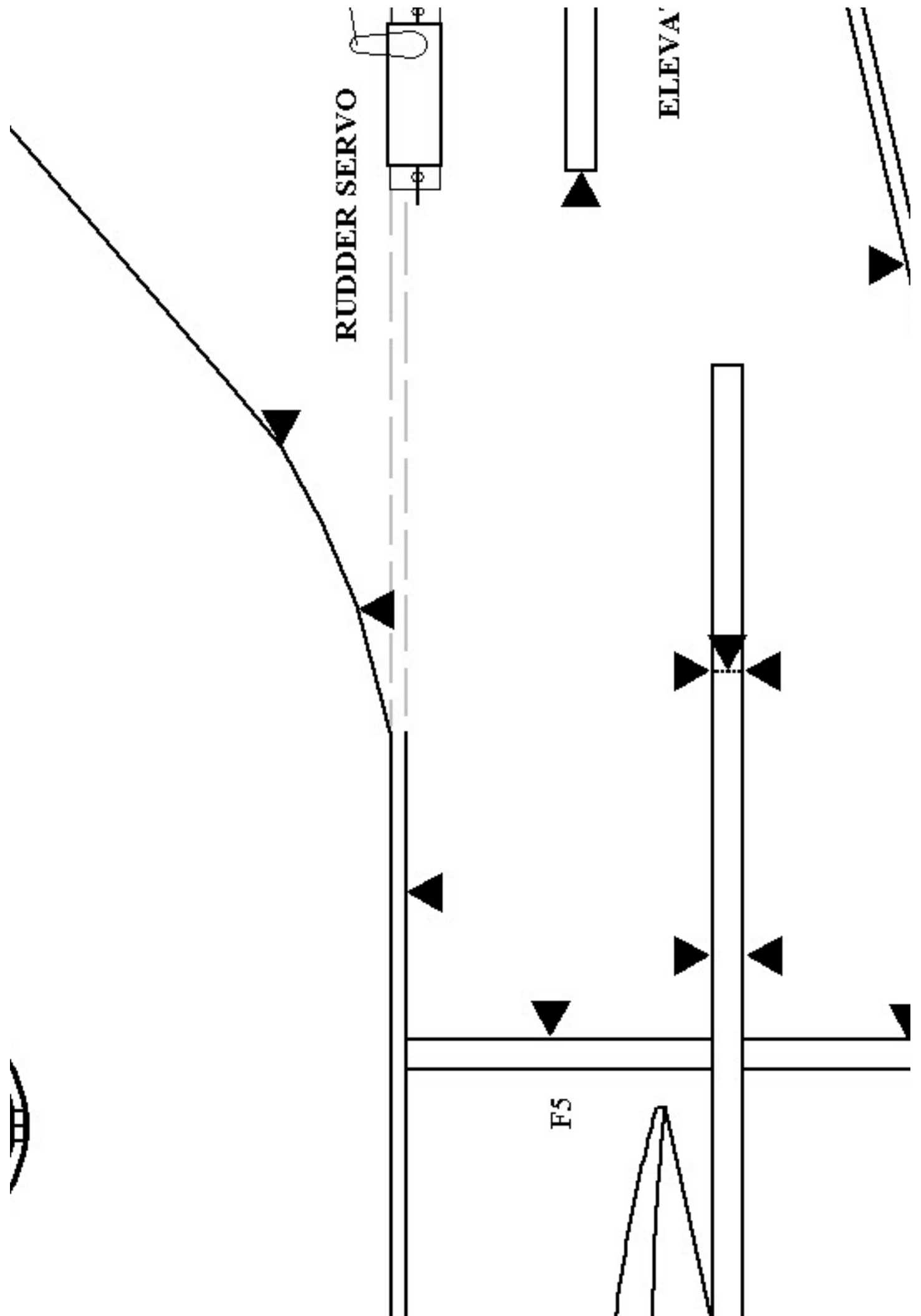

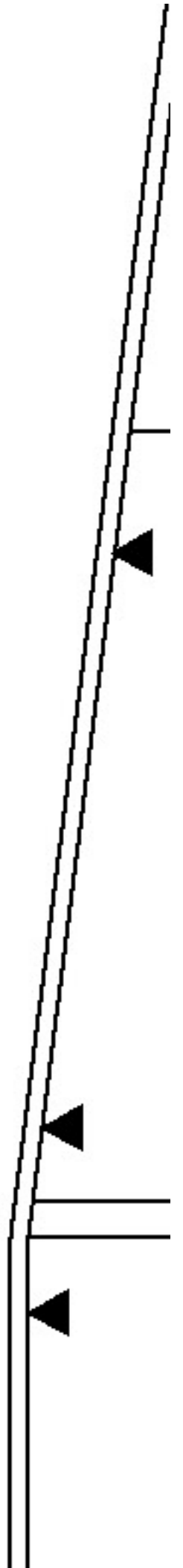

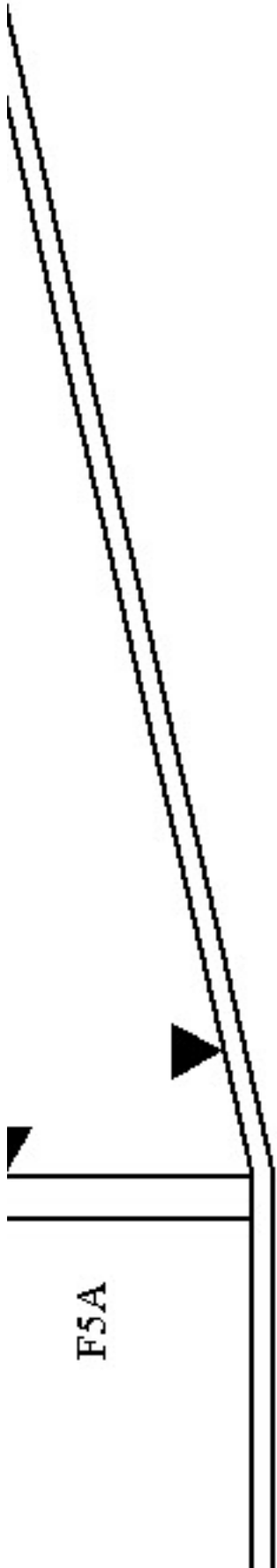

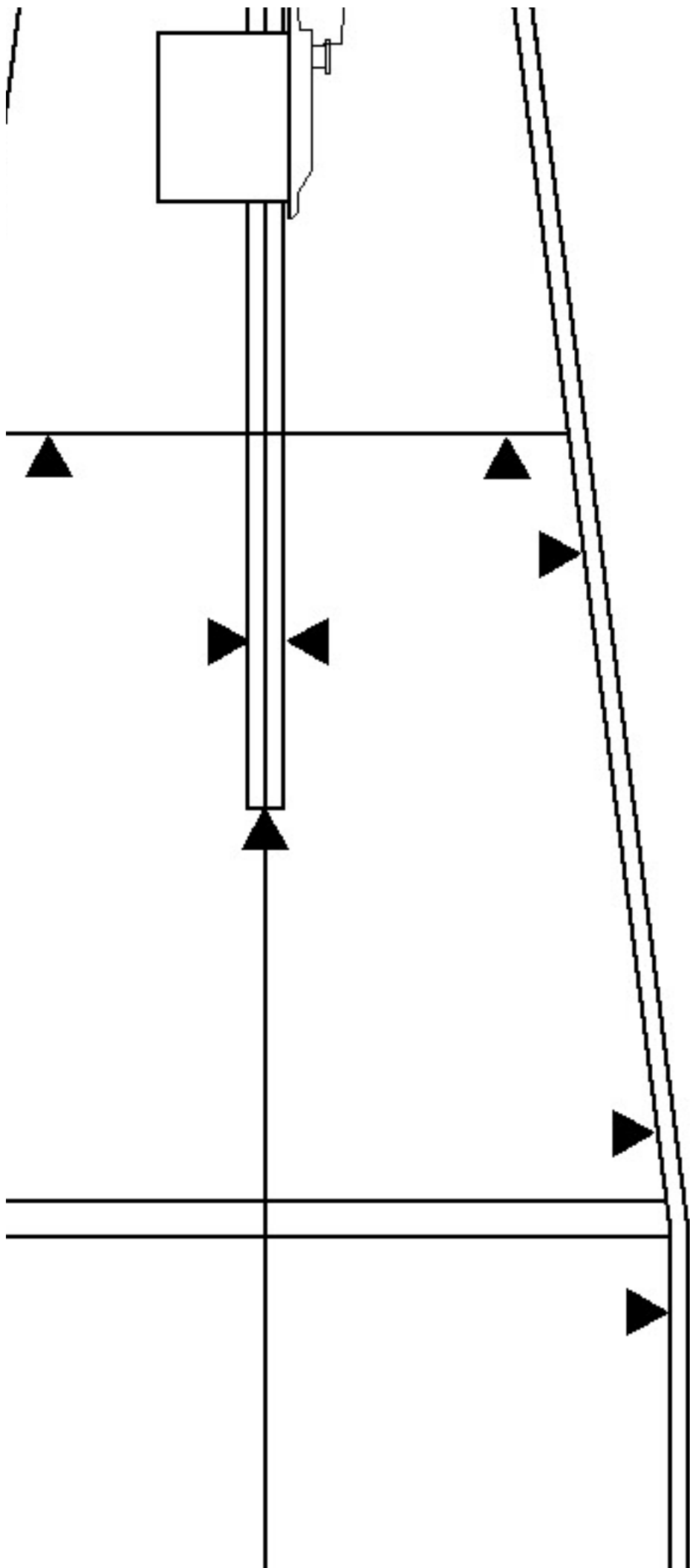

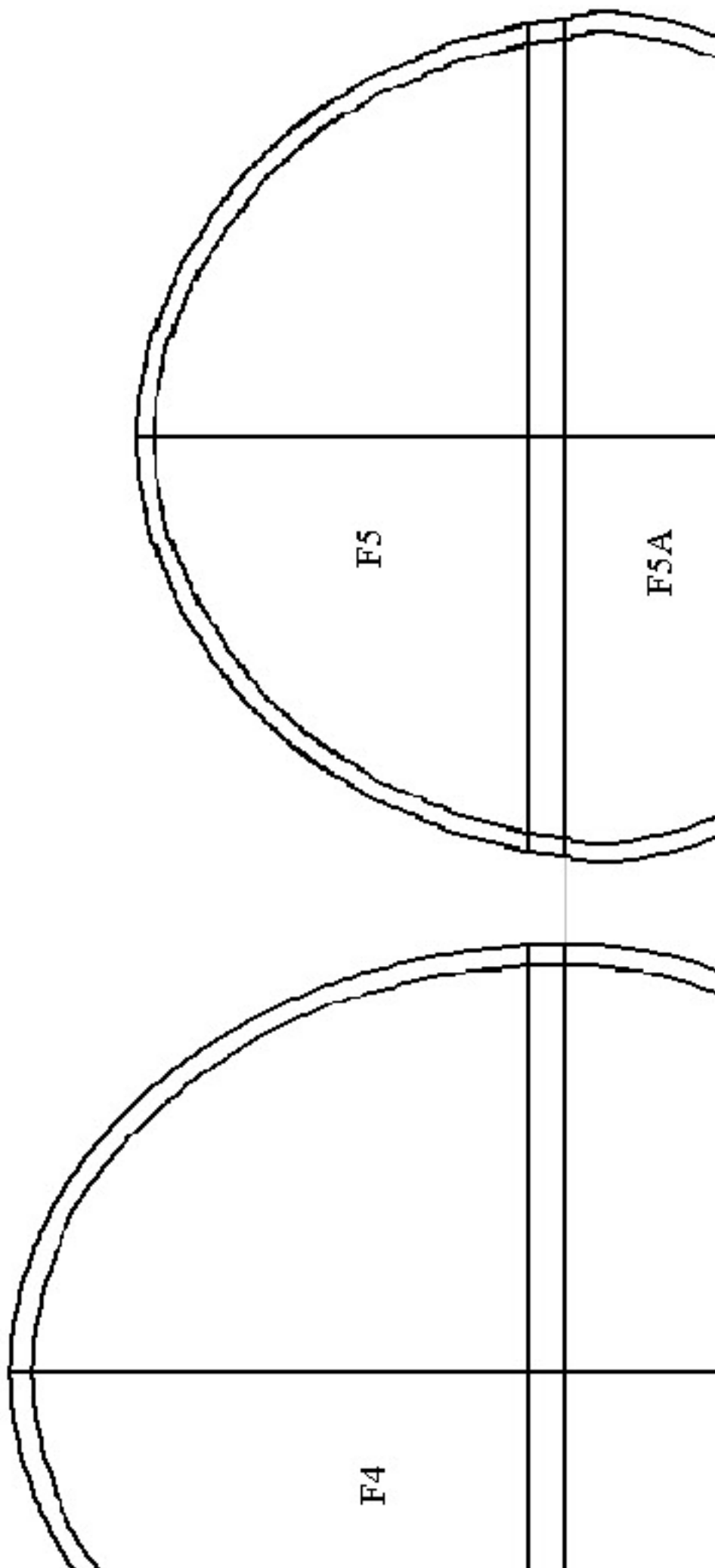

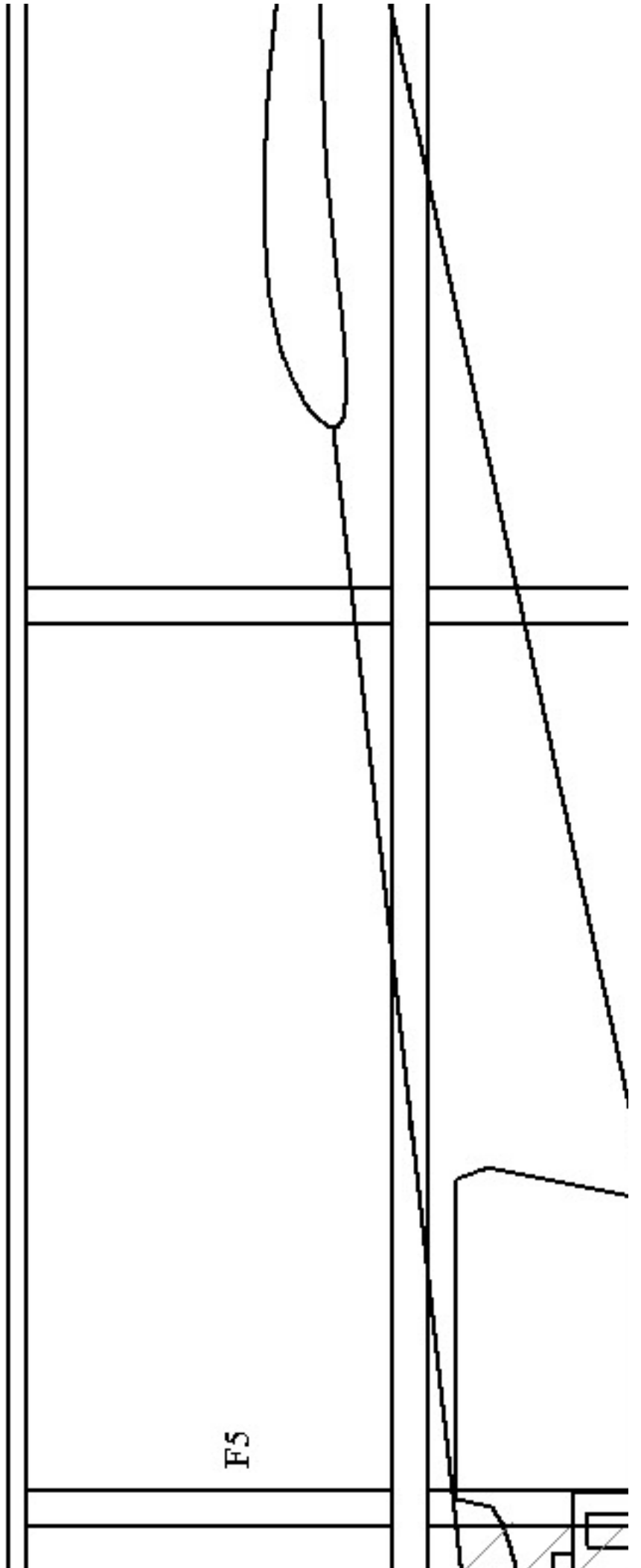

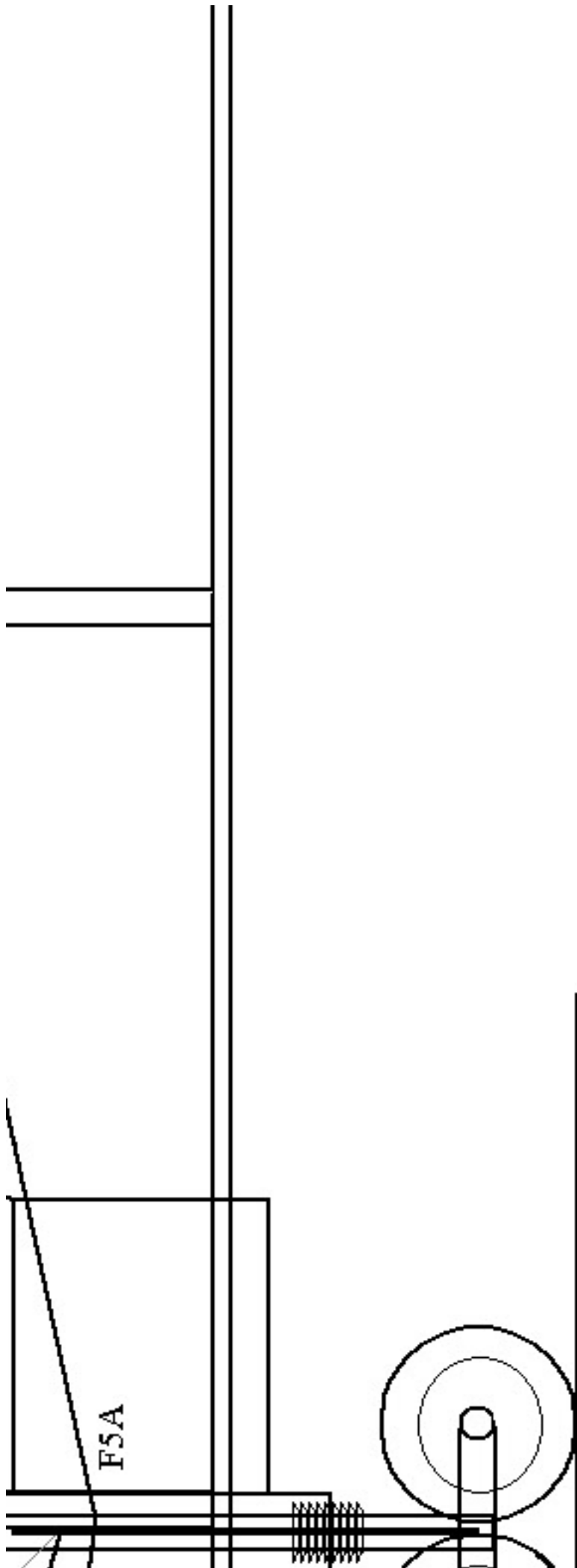

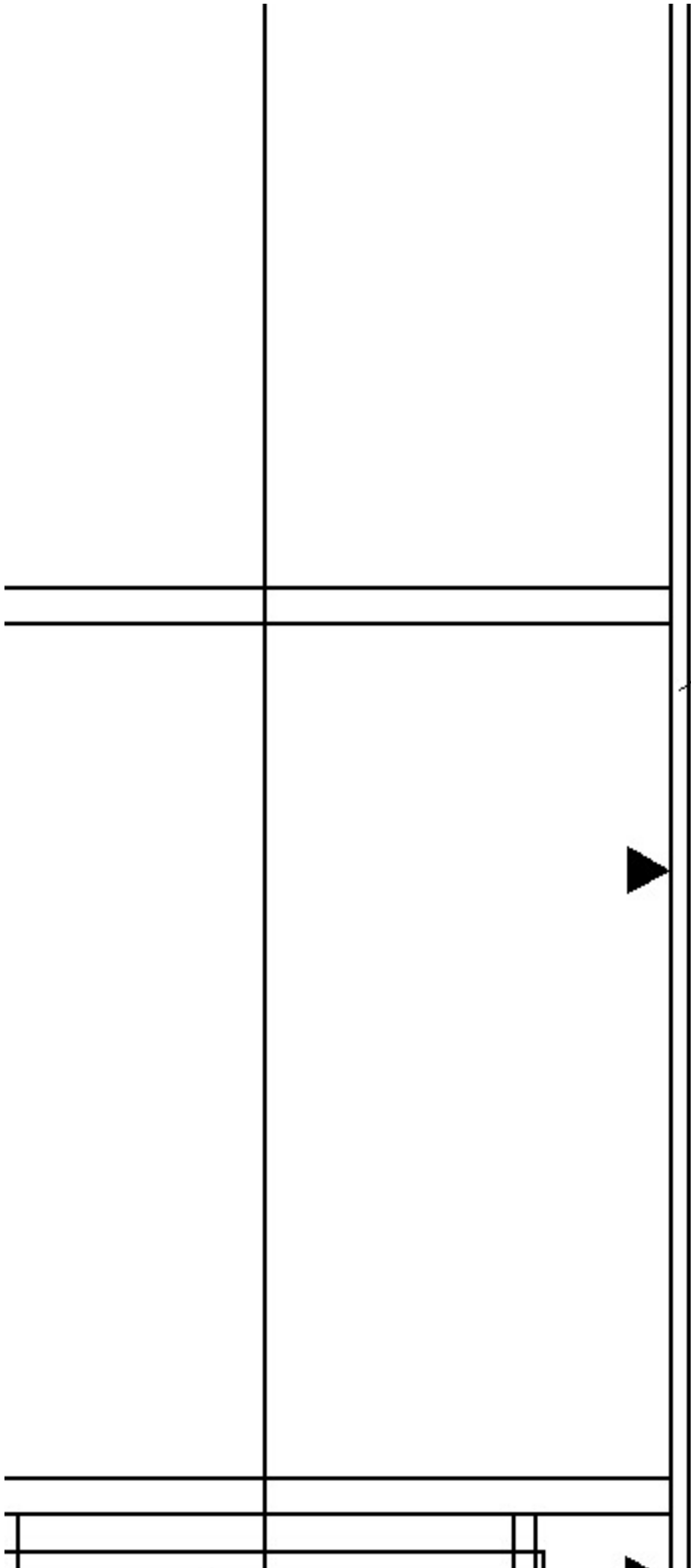

SHEETING IS 3MM DEPRON

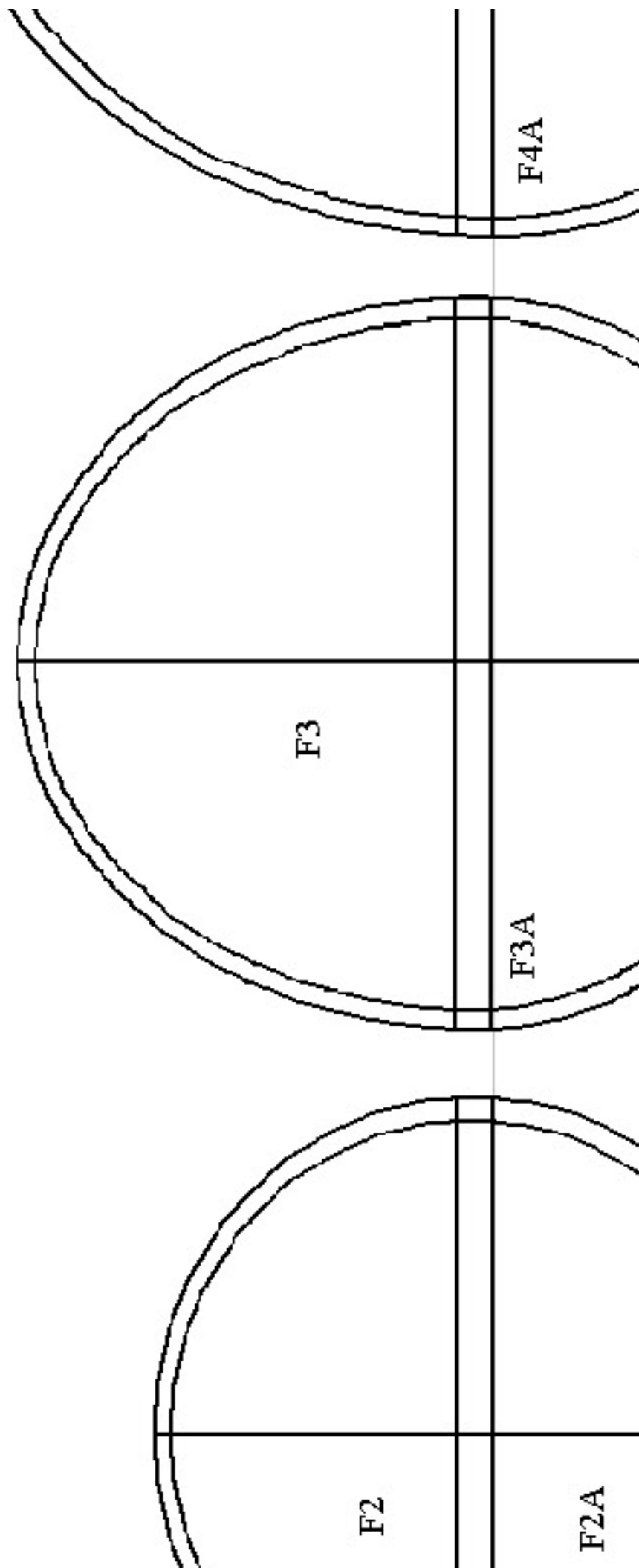



ALL FORMERS 6MM
DEPRON UNLESS
STATED

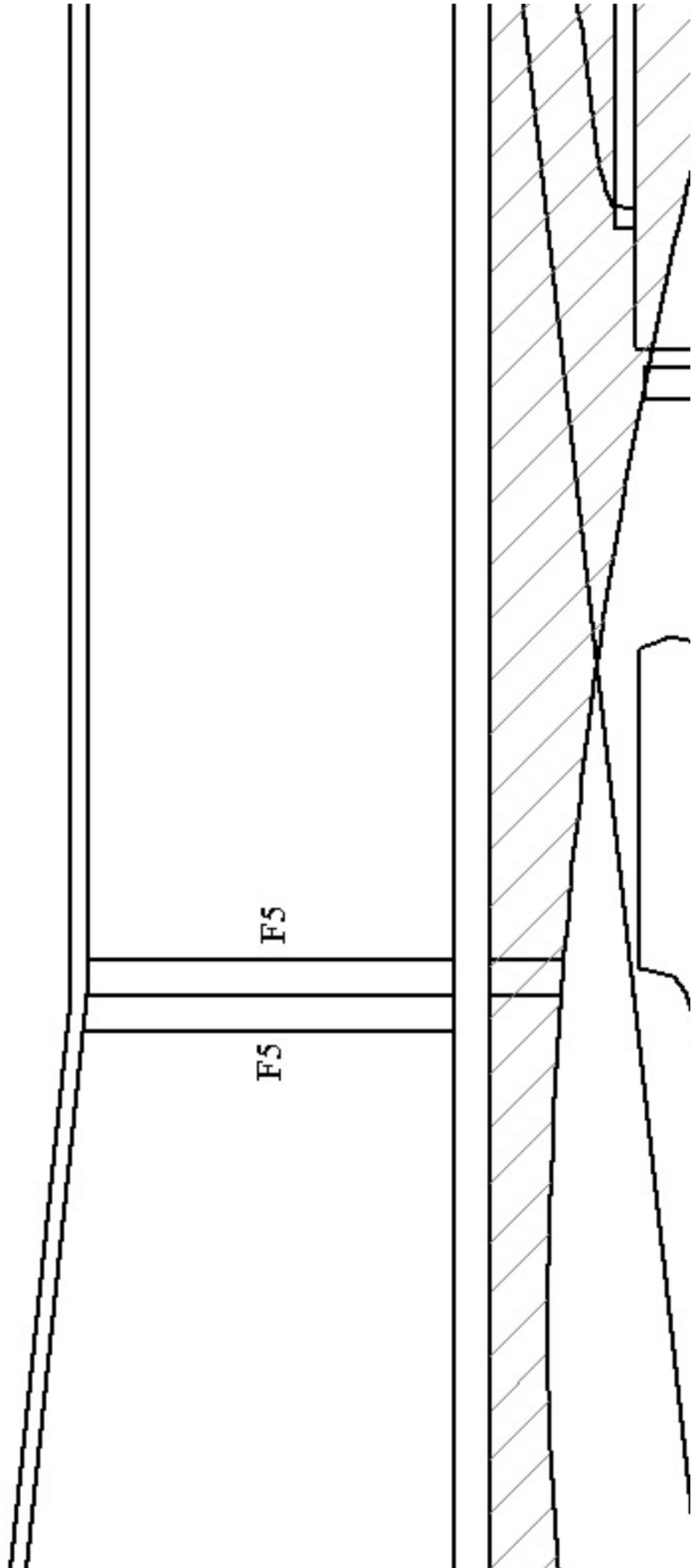

F5

F5

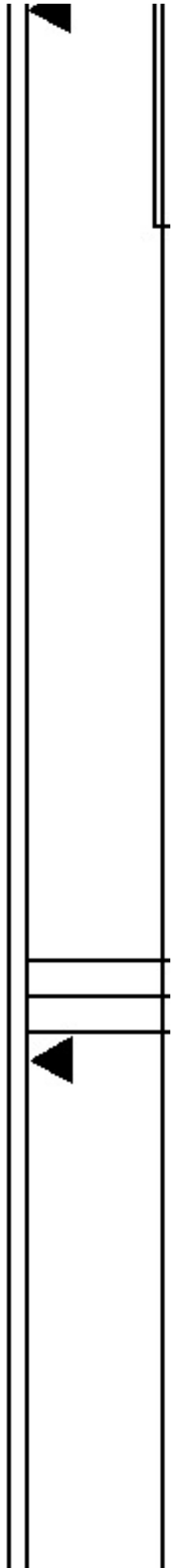
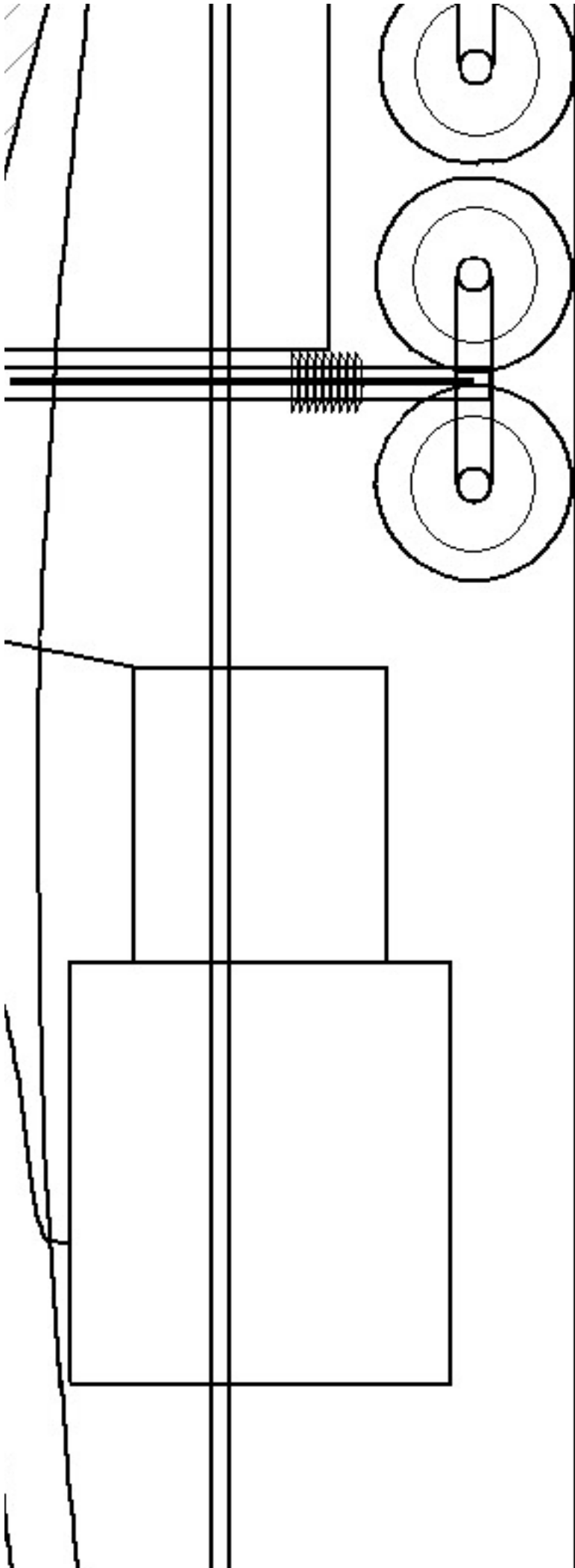

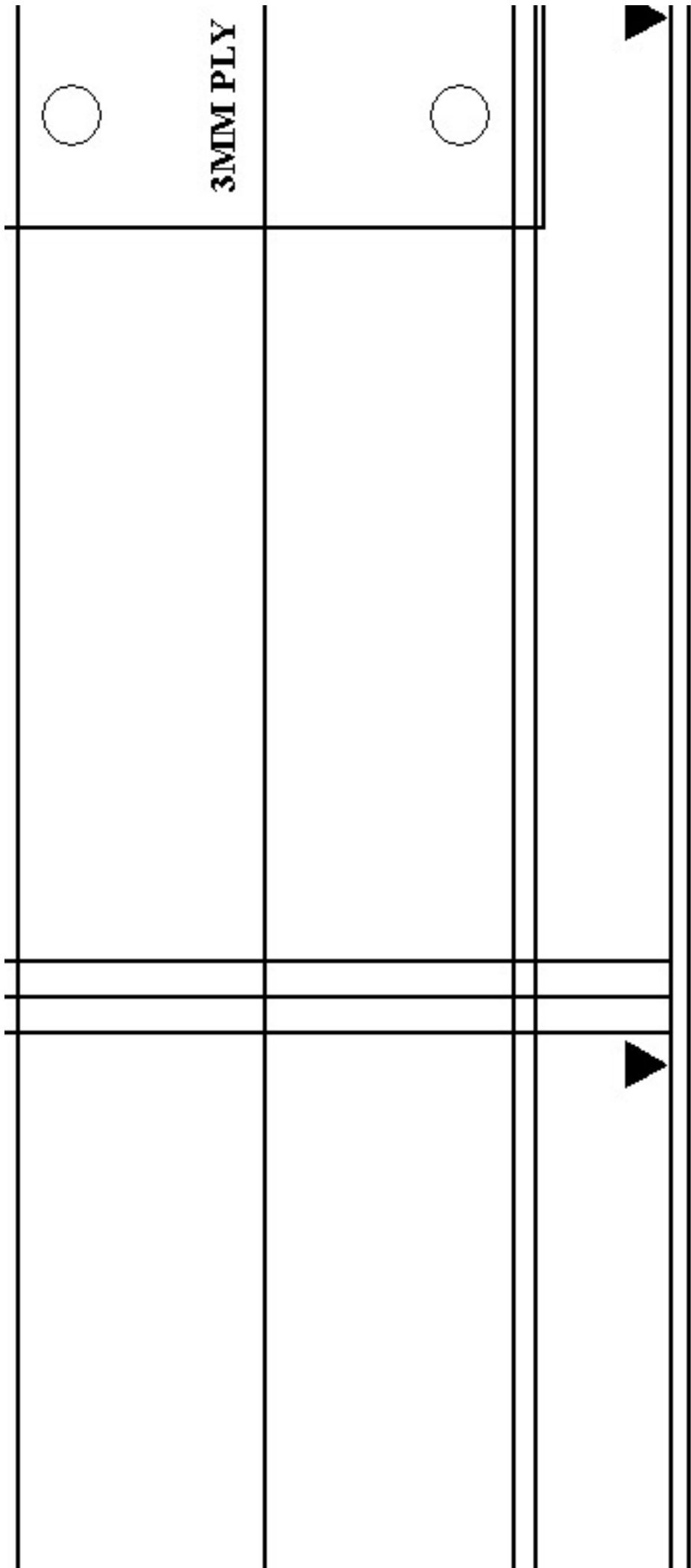

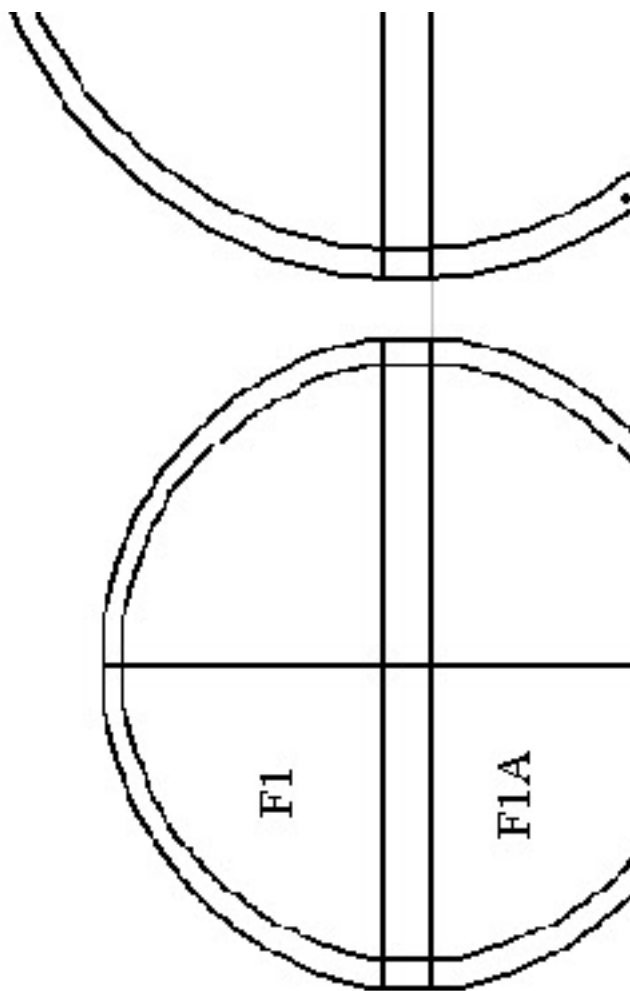

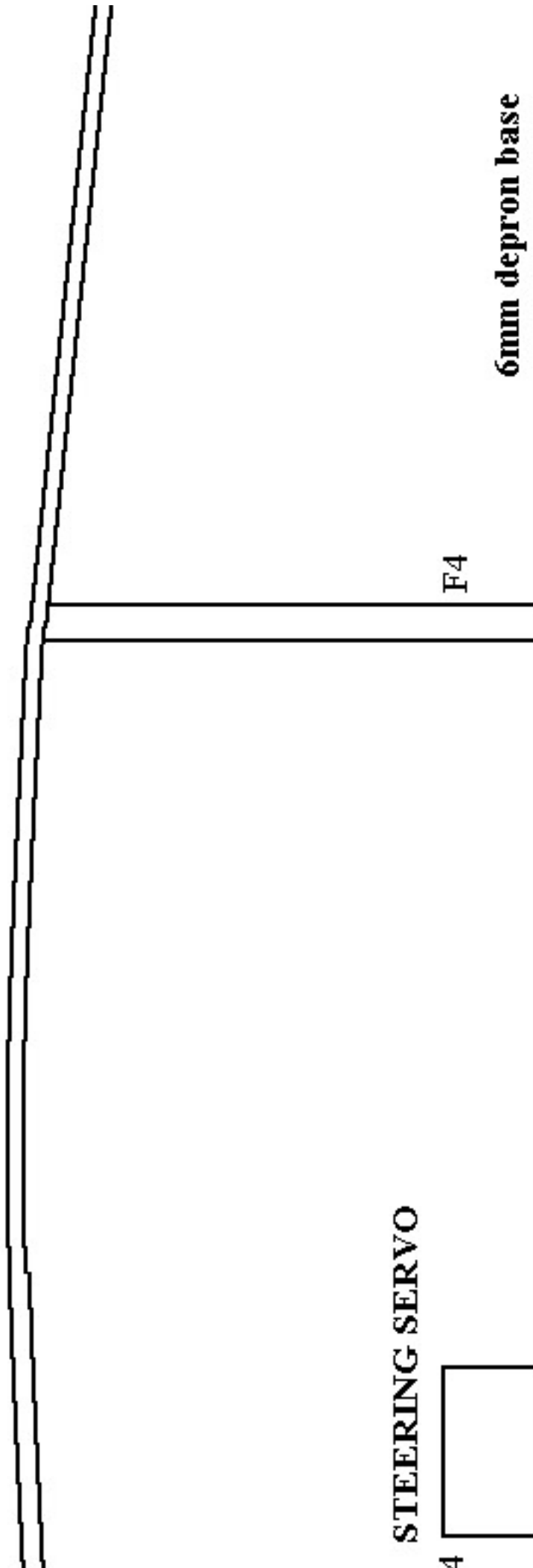

STEERING SERVO

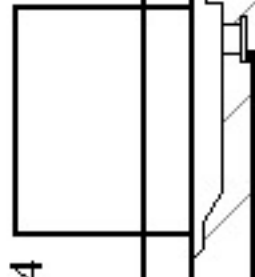

6mm depron base

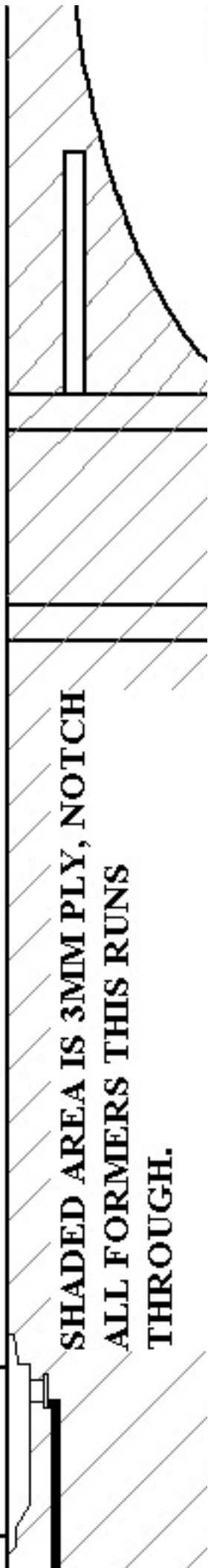

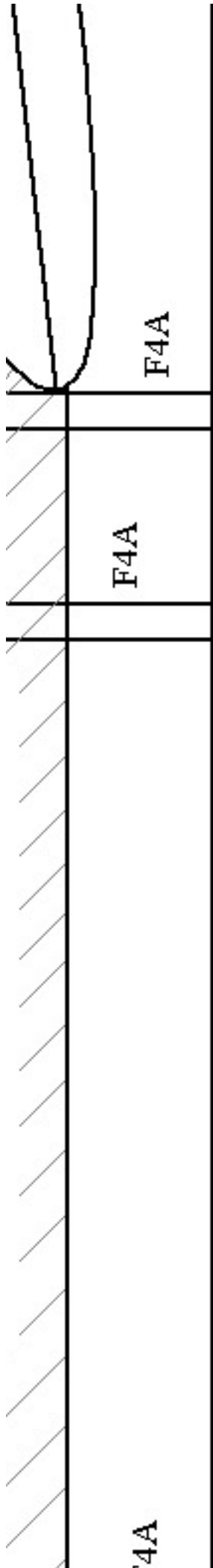

STRAW OVER

SHEETING IS 3MM DEPRON

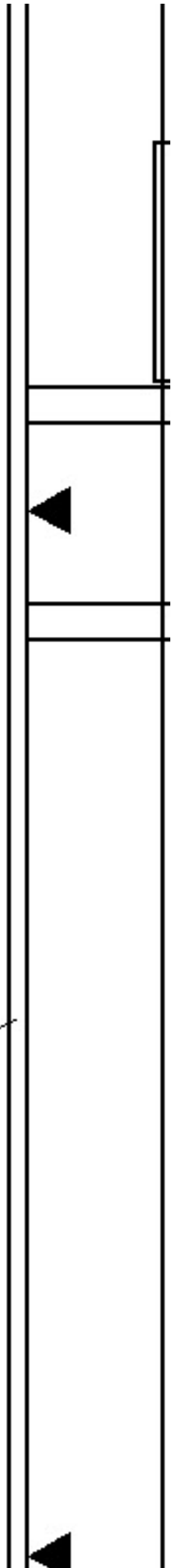

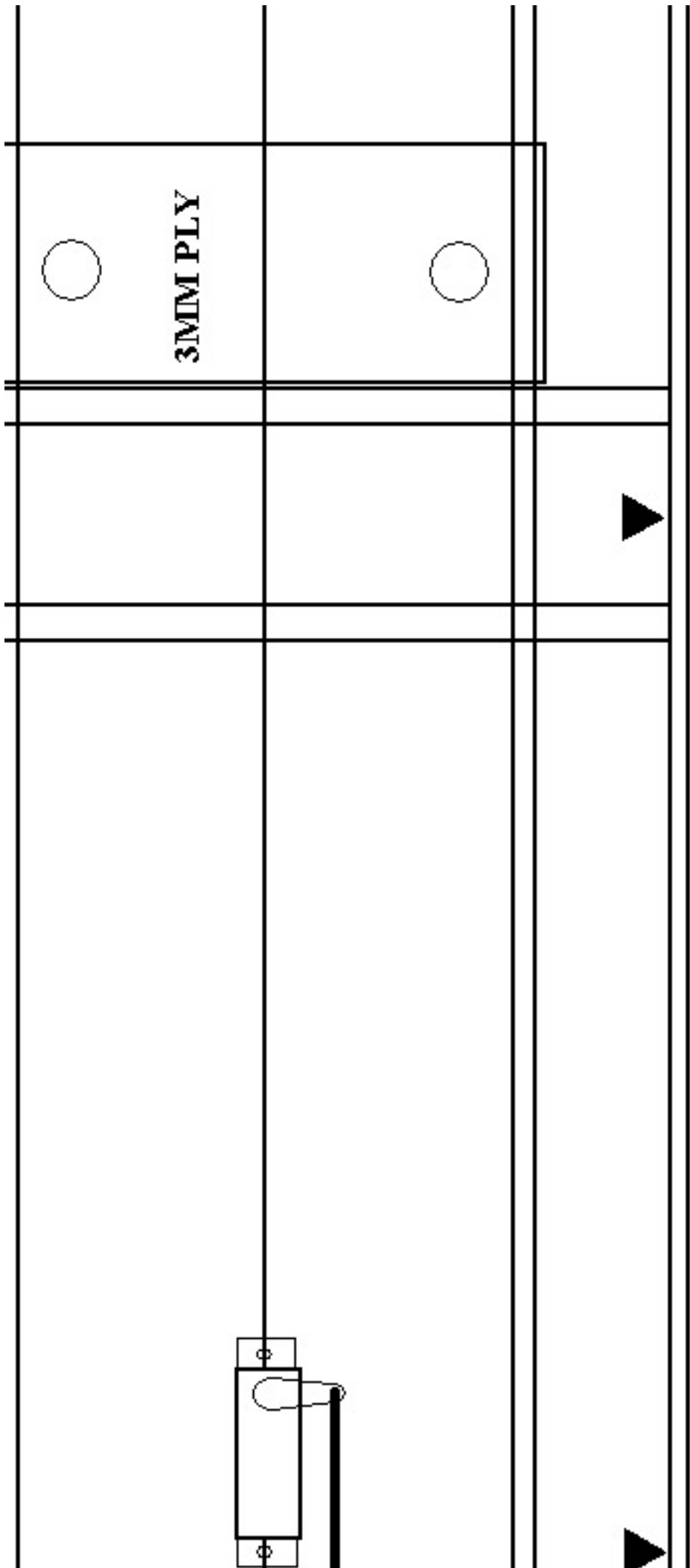

BOEING 747

**SPECS- 61 INCH FUSELAGE
51 INCH WINGSPAN
FOR 55MM EDF OR PUSHER PROP**

DESIGNED BY *BRETT JONES*

SHEET 1 OF 2

COPYRIGHT 2007.

LAMINATIONS OF DEPRON

