

REVISIONS							
ZONE	REV	ECO	DESCRIPTION	CHECK	DATE	ENGR	DATE
ALL	01		ENGINEERING RELEASE	XX	X	XX	X

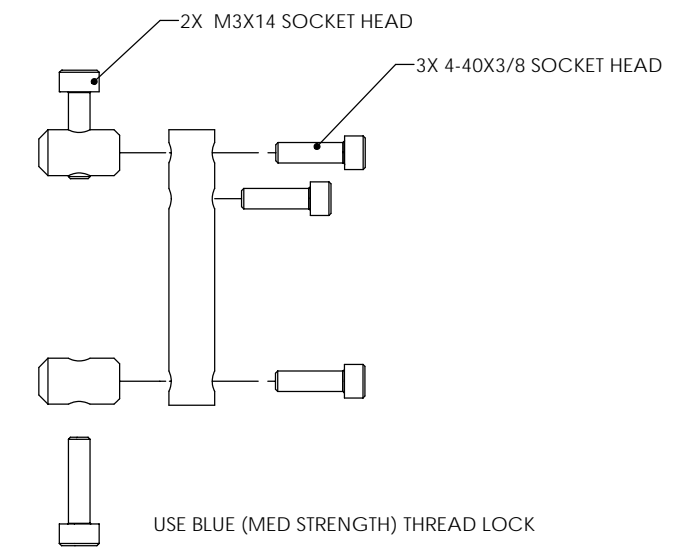

NOTES: UNLESS OTHERWISE SPECIFIED

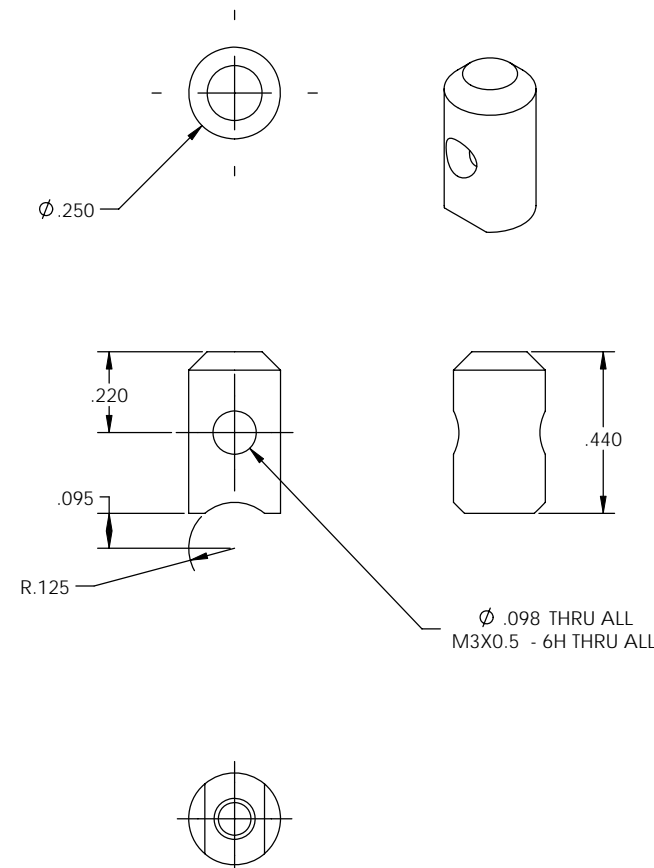
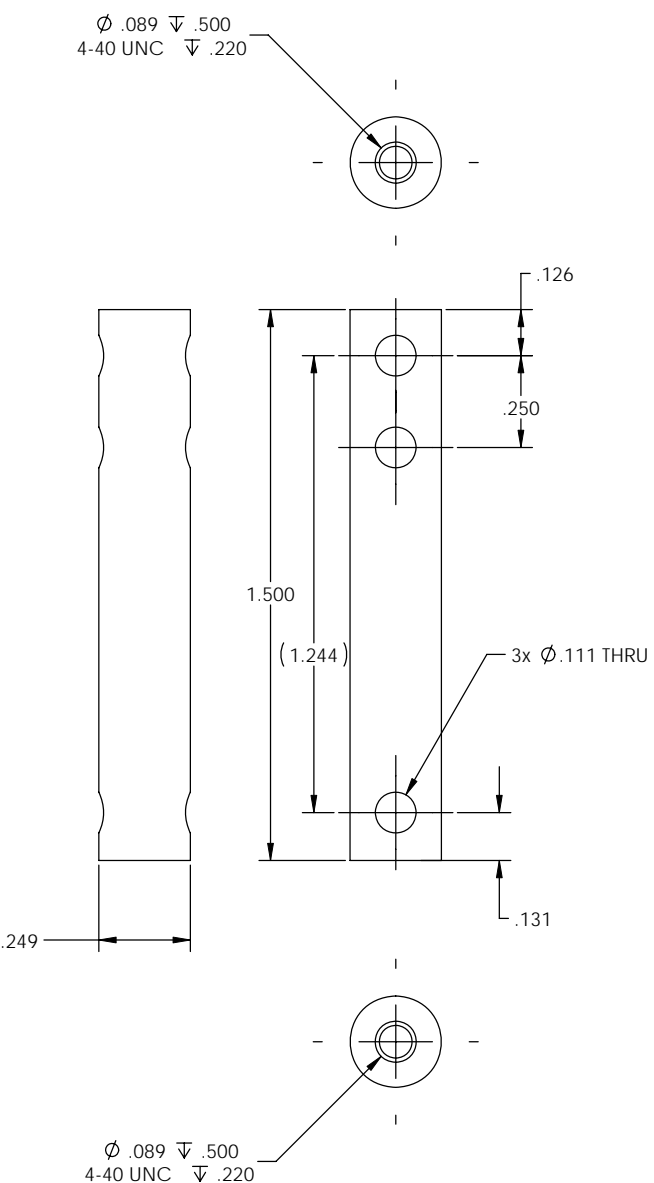
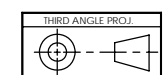

PLOTTED
10/15/07

APPROVALS		DATE	DAVID COOK		10/15/07		DAVID COOK	
DRAWN		DAVID COOK		10/15/07		3 PIECE CRANKS		
CHECKED						3 PIECE CRANKS		
ENGINEER						3 PIECE CRANKS		
DATE						3 PIECE CRANKS		
SCALE: 1/1						SHEET 1 OF 1		